

**DigitTech**

# TWIN TUBE

GFX-1

Tube Guitar Preamp

Owner's Manual

**ADDENDUM  
TO THE GFX-1 TWIN TUBE  
OWNERS MANUAL**

Page 6: Under OUTPUT JACKS, mixing both left and right will not yield the best sound as it cancels out the delay effects.

Page 8: The GFX-1 has a mono effects return, not a stereo return.

Pages 9,10, and 11: All 120 presets in the TWIN TUBE are programmable not just 60. When effects are bypassed, the letters disappear from the display, they are not shown in lowercase letters.

Page 16: The GFX-1 has no Repeat Hold function. Under DELAY PARAMETERS, Delay Time, the maximum delay time is 500 milliseconds not 750 milliseconds. The delay increment is adjustable in 1 millisecond only below 100 milliseconds, above 100 milliseconds the delay is adjustable in 5 milliseconds.

Page 19: Last sentence reads "See Appendix D, ..." This should read Appendix C.

Page 21: The transmit map functions only with the GFX-1FX Foot Controller. There is no optional Studio Remote Controller available.

Page 25: The GFX-1 has no Repeat Hold function.

The TWIN TUBE uses a 4.5 Volt battery for memory retention. This battery should last approximately 3 years.

# TABLE OF CONTENTS

---

Safety Precautions and Warranty .....	inside front cover
Table of Contents .....	1
Introduction and Specifications .....	2
Quick Start .....	3
Front Panel Controls .....	4
Rear Panel Controls.....	6
Making Connections (Direct connections, effects loops) .....	7
Programming (Selecting programs, Creating programs, Creating configurations, Changing names, Store, Title, Compare, Bypass) .....	9
Effects and their Parameters (Compression, Distortion, Equalization, Master Volume, Noise Gate, Effects Loop, Chorusing & Flanging, Delay).....	14
Utility Menu (Speaker Simulator, MIDI functions, Continuous controllers, CC Link Table, Data dump, Foot controller setup, Sets and Patches Factory Settings Table, Factory Preset Restore, LCD Contrast) .....	19
The Foot Controller (Optional) .....	28
The Effects Loop .....	30
Appendix A: EFFECT CONFIGURATION .....	31
Appendix B: USER PROGRAM SHEETS .....	32
Appendix C: STANDARD MIDI CONTINUOUS CONTROLLERS .....	33
Appendix D: DOD / DIGITECH SYSTEM EXCLUSIVE FORMAT .....	34
MIDI Implementation Chart .....	37

# INTRODUCTION

---

DigiTech's new GFX-1 TWIN TUBE Tube Guitar Preamp combines the latest in vacuum tube technology with digital and analog effects. The fat, smooth sound is developed utilizing two 12 AX7 Groove Tubes® as the foundation of the TWIN TUBE's four-stage tube preamp technology. And by combining the vacuum tube sound with up to five of the digital analog effects, the TWIN TUBE is capable of virtually any guitar sound.

## Effects:

- \* Compression
- \* Vacuum Tube Distortion
- \* Clean tube sound
- \* Digital Delay
- \* Chorus
- \* Flange
- \* Noise Gate
- \* 7-band Graphic EQ
- \* Speaker Simulator

## Features:

- \* 120 user-defineable presets
- \* Up to 6 effects at once
- \* 32 character LCD display
- \* Full MIDI control
- \* 4-stage tube preamp technology
- \* 2-12AX7 Groove Tubes®
- \* Foot controller (optional) for access to programs, patches and parameters
- \* 20 Hz to 15 kHz bandwidth
- \* 90 dB S/N ratio
- \* Less than 0.08% THD
- \* Programmable FX loop

Groove Tubes are a registered trademark of GT Electronics, Sylmar, CA

## QUICK-START

---

For best performance from the TWIN TUBE, follow the instructions below. See "Making Connections" (page 7) and related sections for detailed instructions.

- INSTALL** Mount the TWIN TUBE in a rack with the provided screws. Rubber feet have also been affixed to the unit for free-standing use.
- APPLY POWER** Route the power cord away from audio lines to prevent interference. Connect to AC outlet.
- CONNECT CABLES** Connect guitar input and output cables to the appropriate jacks.
- CONNECT FOOT CONTROLLER** Plug in the optional foot controller to the rear jack. See "Foot Controller" (page 31).
- ADJUST INPUT** Turn on the TWIN TUBE. Set the instrument, amp, and/or mixer to loudest operation that will be used. Adjust the TWIN TUBE input level until the red headroom LED comes on occasionally.
- ADJUST OUTPUT** Set the TWIN TUBE output level to the desired volume.
- EFFECTS LOOPS** Connect any external effects devices to the TWIN TUBE effects send and return jacks. NOTE: external devices must be unity gain, such as the DigiTech IPS-33B Intelligent Harmony Machine. See "External Effects Loops" (Page 8)
- CONNECT MIDI CONTROLLER** Plug in a MIDI controller, sequencer or synthesizer to the rear MIDI IN jack, if desired. See "Utility Menu" (page 21).
- SELECT PROGRAM** Choose any program or factory preset by using the UP and DOWN PROGRAM buttons, foot controller, or MIDI controller.

# FRONT PANEL

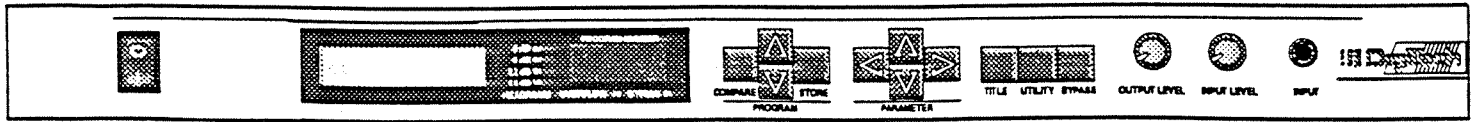

**POWER** Turns the TWIN TUBE on and off. When turned on, the unit returns to the same program as when it was shut off.



**LCD** 16-character, two-line liquid crystal display shows the current program title, configuration, or effect and utility parameters.

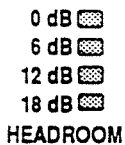

**HEADROOM** Four LEDs display the input signal level. The best signal level is when the green LEDs light and the red LED peaks occasionally. See "Making Connections" (page 7).



**OVERFLOW** Single LED indicates too much internal gain, overloading the processor. Turn down the programmable mix and effects levels.



**BYPASS LED** Single LED shows effects are muted and a dry input signal is being sent directly to the output.



**PROGRAM NUMBER LED** Three-digit Light Emitting Diode displays the selected program number.



**COMPARE** Compares current program being edited to the original program.



**PROGRAM** Increments and decrements program numbers. Wraps around from 1 to 120.

**PROGRAM**



**STORE** Saves new effect configurations to a selected program number, and is used to copy to another preset location. See "Store" (page 10).

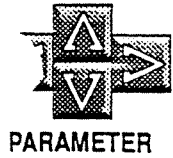

**PARAMETER** LEFT and RIGHT buttons select the next effects parameter, pull up the next utility function, or move to next title letter.

UP and DOWN buttons change effect parameter values, utility parameters, or title letter. See "Programming" (page 9) and "Utility Menu" (page 19).



**TITLE** Allows the name of the current program to be edited. See "Title" (page 12).



**UTILITY** Displays the utility menu on the LCD. Includes MIDI channel select, continuous controller links, MIDI mapping, program transmitting, footswitch programming, and restoring factory presets. See "Utility Menu" (page 19).



**BYPASS BUTTON** Shuts off effects and sends a dry signal direct to the output.



**OUTPUT LEVEL** Adjusts the output signal to the desired level. See "Making Connections" (page 7).

Individual effect output levels can also be programmed internally. See "Effects and Their Parameters" (page 14).



**INPUT LEVEL** Adjusts the strength of the received stereo or mono signal to an optimum level. See "Making Connections" (page 7).



**INPUT JACK** Standard 1/4-inch T-R-S jack for guitar or line-level signals. Rear INPUT is bypassed when front INPUT is used. See "Making Connections" (page 7).

# REAR PANEL



**INPUT JACK** Single ¼-inch Tip-Ring-Sleeve (T-R-S) jack for balanced or unbalanced instrument or line signals. Mono input signal only.

**OUTPUT JACKS** Two ¼-inch T-R-S jacks for stereo output to amplifier or mixing console. Use the left (mono) jack for mono only, or a mix of both left and right for best mono sound.



**EFFECTS SEND** Single ¼-inch T-R-S jack to send signals from the TWIN TUBE to external effects devices.

**EFFECTS RETURN** Single ¼-inch T-R-S jack to return signals from external effects devices to the TWIN TUBE.

**FOOT CONTROLLER JACK** Six-pin DIN jack to connect the optional DigiTech foot controller. Pedal functions can be programmed. See "Utility Menu" (page 27).



**MIDI IN JACK** Five-pin DIN for standard MIDI cable. Receives MIDI control data. See "Utility Menu" (page 21).



**MIDI THRU/OUT JACK** Five-pin DIN for standard MIDI cable. Sends MIDI control data. See "Utility Menu" (page 21).



**FUSE** Accessible from the rear panel. **USE ONLY THE FUSE VALUE INDICATED ON THE REAR PANEL.**



# MAKING CONNECTIONS

The TWIN TUBE creates the ultimate in stereo or mono sound effects from instruments or line signals.

**DIRECT CONNECTIONS** For direct connections, configure the instrument, TWIN TUBE and amplifier as follows:

**Mono In, Stereo Out** Connect the instrument to the TWIN TUBE front or rear input jack. Connect the left and right outputs to the amplifier or mixer inputs. To match the sound of any speaker or amplifier, use the speaker simulator function (page 20).

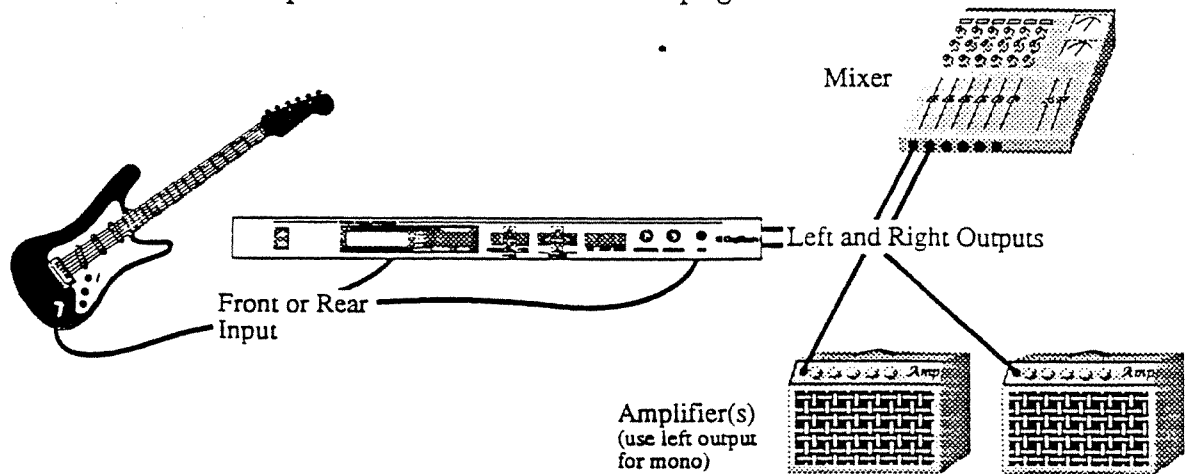

## TWIN TUBE EFFECTS LOOPS

With its own effects send and ~~stereo~~ <sup>MONO</sup> return, the TWIN TUBE can be set up to use other effects devices in a programmable effect loop.

Connect the instrument to the TWIN TUBE input. Connect the TWIN TUBE effects send to the external device, then back to the TWIN TUBE effects return.

The effects send and return operate at line level only, so the external device must be set for unity gain at a line level output.

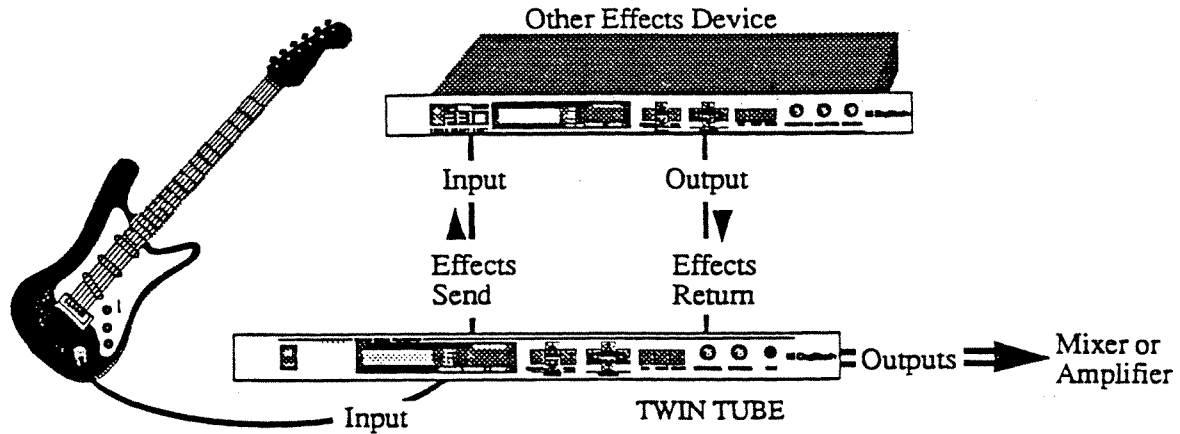

### ADJUST INPUT AND OUTPUT



**Input** After connecting the TWIN TUBE input and outputs, set the instrument, amp, and/or mixer to loudest operation that will be used. Adjust the TWIN TUBE INPUT LEVEL so the red headroom LED only occasionally comes on. The red LED comes on just before the signal is clipped.



**Output** Turn up the OUTPUT LEVEL to the optimum level for the amplifier or mixer, being careful to avoid overload.

# PROGRAMMING

**SELECTING PROGRAMS** While reading this section, you may refer to this Programming Map.

Programming Map

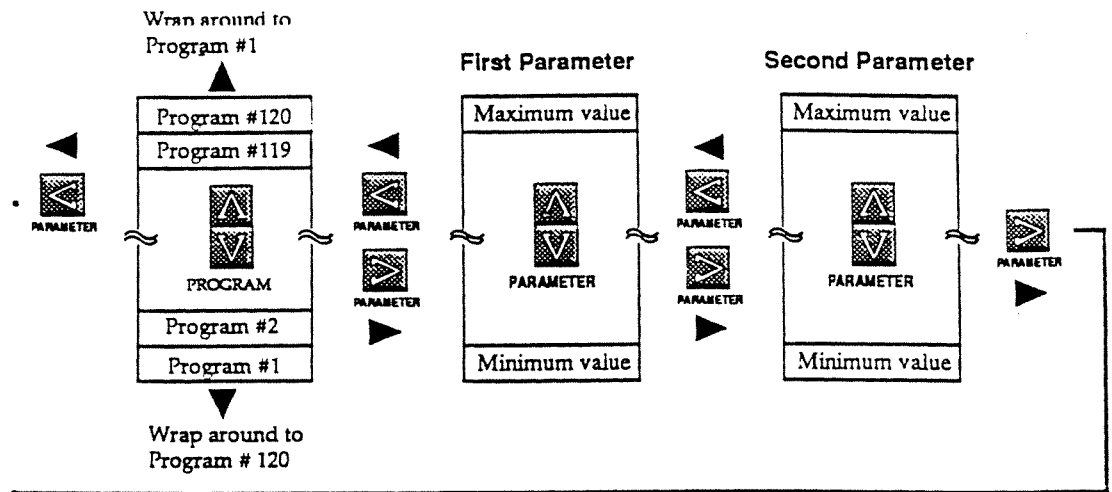

Press the up or down program buttons on the front panel to change programs. Program numbers will appear on the red program LED, and program names and configurations will appear on the LCD.

The program numbers will wrap around from program 1 to program 120 when using the PROGRAM DOWN button, and from 120 to 1 when using the PROGRAM UP button.

The first 60 slots (programs 1 through 60) can be user-programmed to create custom sounds or variations on the factory preset programs. When shipped from the factory, these slots contain copies of the preset programs.

DigiTech has provided 60 preset effects (programs 61 through 120) which represent a wide range of versatile configurations designed and named by a panel of studio musicians and technicians.

**CREATING PROGRAMS** To customize a program, start by selecting one of the first 60 slots. Modify the preset as desired, change the name, then store it.

BigFatChunkO'Tub  
CP TUBES FLG

Notice the LCD display – the effects types that are available in this preset are shown, and those in capital letters are currently on, those with lower case letters are currently off.

Select a Preset Program Each program is unique with different effects and parameters. Choose any program and begin experimenting to create distinctive sounds.

Changing Parameters Press the LEFT or RIGHT PARAMETER buttons to select an effect parameter to be changed. The display will read:

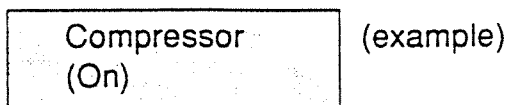

Parenthesis appear around the original effect parameters so they can be reset if a modified effect doesn't sound right. Each effect can also be bypassed. If bypassed, the effect's options will not be displayed.

Push the PARAMETER UP and DOWN buttons and the value of the selected parameter changes. Set the effect parameter to the desired value.

While adjusting the effect parameter value, play the instrument to hear what happens as the value is changed. The COMPARE button can also be used to see how the new parameters sound as compared to the original un-edited program. See "Compare" (page 12).

Changing the Name After creating a new effect configuration, give it a name. Press the TITLE button and a cursor appears under the first character in the program title. Move the cursor through the title using the LEFT and RIGHT PARAMETER buttons. Change characters with the PARAMETER UP and DOWN buttons. Press the TITLE button again when finished. See "Title" (page 12).

Store After editing the effect parameters and changing the title, press the STORE button to save the changes. The display will read:

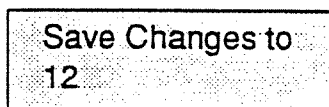

The current program number will be shown if a user slot (1-60) is being edited. The new program can be stored to a different number by pressing the PROGRAM UP or DOWN buttons.

If a preset slot (61 - 120) is being edited, the corresponding user slot number in the first bank (between 1 and 60) will be shown

when the STORE button is pressed. This number can also be changed by pressing the PROGRAM UP or DOWN buttons.

Each user slot comes from the factory with a copy of the preset 60 slots higher. For example, user slot 12 is a copy of program 72.

To save to the displayed program number, press the STORE button again. The display will read:

..... Storing .....

**Cancelling Store** If the store button was accidentally pressed, do not press STORE again, but escape back to the editing mode by pressing the COMPARE button.

**Aborting Changes** If the program has been edited but not stored, the TWIN TUBE will cancel the changes when the PROGRAM button is pushed. To prevent losing edited programs, the display will read:

To save changes  
press (STORE)

At this point there are three options:

1. Save the changes by pressing the STORE button.
2. Abort the changes by pressing the UP or DOWN PROGRAM buttons.
3. Escape from the warning display by pressing the COMPARE button. The display returns to the editing mode.

When new programs are stored, make photocopies of the "User Programs" chart (Appendix B) and write your programs down on the copies. This will help keep track of all the programs and sounds that are stored on the TWIN TUBE.

**Title** Program titles can be changed by pressing the TITLE button. The display will read:

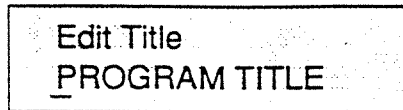

A cursor appears under the first character in the title. Move the cursor through the title using the LEFT and RIGHT PARAMETER buttons.

To change characters in the title name, press the UP or DOWN PARAMETER buttons. Up to 16 characters can be used in each name using the following letters and symbols:

*space* ABCDEFGHIJKLMNOPQRSTUVWXYZ  
abcdefghijklmnopqrstuvwxyz  
0123456789 ! " # \$ % & ' ( ) \* + , - . / :  
*left arrow, right arrow* ; < = > ? @ [ ] ^ \_ ' { | }

After changing the title, press the TITLE button again. The TWIN TUBE will return to the mode it was in before the title button was pressed. To save the title and the new program, press the STORE button.

**Compare** The COMPARE button is used while editing to contrast the new effect configuration against the original un-edited program.



While editing a program, push the COMPARE button. If nothing happens, no changes have been made to the program. If changes have been made, the display will read:

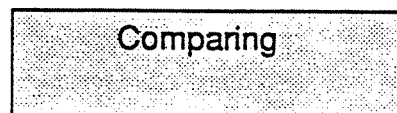

Play the instrument to hear the sound of the original program. Press the COMPARE button again and the display returns to the edited version to hear its sound and make changes.

Using the COMPARE button, toggle back and forth between the original program and the modified version, making changes until the sound is just right.

Press Compare to Escape The COMPARE button is also used as an escape button from the following modes:

1. When the STORE button is accidentally pushed, press COMPARE to escape back to editing mode.
2. When a wrong program number is pushed using the optional studio remote controller, press COMPARE to escape and start over.

**Bypass** When the BYPASS button is pressed, all effects are shut off and a dry signal is relayed. This is great during performances, where effects can be turned on or off with the push of a button.



BYPASS

Press the BYPASS button again to toggle effects back on. See Foot Controller operation (page 31) for a description of the Footswitch Bypass action.

## EFFECTS & THEIR PARAMETERS

---

The TWIN TUBE is a highly-complex processor which converts analog signals (from your pickups) into digital code. Computer circuitry manipulates this digital code to create unlimited sound effects, then converts the output signal back to analog. Up to six digital and analog effects can be used simultaneously.

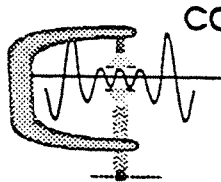

### COMPRESSION

Compression is an effect which adjusts the source's dynamic range (the difference between the loudest and quietest sounds). By compressing the range, notes can be sustained longer and the sound will be tighter.

**Compression Bypass** Enables and disables the compression

**Compression Amount** Varies the amount of compression. A low setting gives a full, natural-sounding dynamic range. A high setting provides a tight heavy metal sound.

**Compression Level** Varies the overall level from the compressor

**VACUUM TUBES** Vacuum tubes create a warm, rich sound

### TUBE PARAMETERS

**Tube Bypass** Enables and disables the distortion.

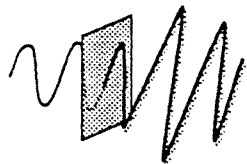

**Tube Bias** Selects between clean or dirty bias settings.

**Tube Gain** Controls the amount of gain (overdrive) entering the tube stages.

**Tube Saturation** Controls the amount of gain (overdrive) within the third tube stage.

### ANALOG EFFECTS

**EQUALIZATION** Equalization is used to compensate for frequency deficiencies and to control an instrument's tonal qualities.

**EQ Bypass** Enables and disables the equalizer. EQ is flat when bypassed.



The TWIN TUBE provides a seven-band programmable equalizer. Each of the seven bands is adjustable in 1 dB steps from 12 dB of cut to 12 dB of boost.



**MASTER VOLUME** Controls the overall level of the TWIN TUBE.

**NOISE GATE** Gates, or shuts off, the output when the input signal falls below a certain level. Useful for eliminating random noises when you're not playing.

**NOISE GATE PARAMETERS**  
On/Bypassed

Enables or disables the noise gate.

Gate Threshold



Sets the threshold (signal level) below which the noise gate "kicks in" and attenuates the signal. The lower the threshold is set, the longer a sustain will hold while fading out, but the more hum or finger noise from your guitar or other effects might get through while you're not playing.

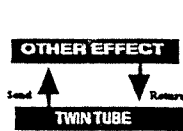

**EFFECTS LOOP**  
In/Out

The TWIN TUBE Effects loop allows you to add an external effect into the TWIN TUBE effects chain.

**DIIGITAL EFFECTS**



**CHORUS**

Simulates a chorus of instruments playing at different tones. Created by splitting the signal, detuning and using a long delay on one, then joining it with the original.

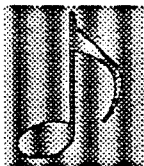

**FLANGE**

Classic sweeping "jet-airplane" effect originally produced by slowing tape reels by pressing against the flanges. The TWIN TUBE creates flanging by splitting the signal, using feedback and a small delay on one portion, then re-joining it with the original.

**CHORUS/FLANGE PARAMETERS**  
LFO Sweep Rate

Low Frequency Oscillator (LFO) sweeping speed of the delay tap across the set delay time. Adjusts the amount of pitch shifting in both chorus and flange effects.

LFO Sweep Depth

Amount of LFO delay time travelled by the delay tap. Adjusts the depth of pitch alteration.

Chorus Delay

Time delay of the chorus effect.

LFO Waveform

The LFO changes the delay time in a regular, repeating wave. Its waveform can be set to one of three shapes:

1. Sawtooth
2. Sine wave
3. Logarithmic

**Flange Feedback** Amount of flange effect fed back into the original signal. More feedback will give a sharper, more metallic flanging sound.

**Flange DelayTime** Time delay of the flange effect.

An suggestion for a good flanging sound is: Delay = 10msec, Sweep Rate = .40 Hz, Depth 2.60 msec, Feedback = available feedback levels: 0%, 15%, 30%, 45%, 60%, 75%, 80%, 99%.



**DELAY** Delay is the time between the original signal and an echo. There is an infinite repeat function, Repeat Hold, which can be activated by the Foot Controller. The TWIN TUBE provides Delay and Multi-Tap Delay effects with five programmable delay parameters:

#### DELAY PARAMETERS

**Delay Time** Amount of delay time between echoes. Shortest delays provide a double or quick slap effect. Longer delays create an echo effect. The TWIN TUBE provides a delay range from 0 to 750 ms user-selectable in 1 ms increments.

**Feedback** Amount of signal internally fed back in the delay. Feedback determines the number of times the echo will repeat.

**Repeat Hold** Allows a button on the Foot Controller to hold and repeat an echo from when the button is pressed until it is pressed again.

Various effects can be produced within the following approximate delay time ranges:



<b>Doubling</b>	20 to 60 milliseconds of delay, with no modulation
<b>Chorus</b>	20 to 60 milliseconds of delay with modulation
<b>Slapback</b>	60 to 200 milliseconds of delay
<b>Echo</b>	200 milliseconds and longer

**Comb Filter and Flange** A comb filter is simply a delay time of 2 to 15 milliseconds. The reason that it's called a comb filter is that as you change the delay time, certain frequencies are notched out by phase cancellation, and a graph of the frequency response looks like the teeth of a comb. This causes a metallic, resonant type sound. A flanger is simply a sweeping comb filter.

**MIX** Adjusts the ratio between the wet signal and the dry signal.

# UTILITY MENU

Press the utility button to access the Utility Menu:



1. Speaker Simulator selection
2. Speaker Simulator Setup Menu
  - A. Simulator User programmable settings U-1 — U-5
  - B. Return to Utility Menu
3. MIDI Setup Menu
  - A. Select MIDI Receive channel
  - B. Set Program Receive Map
  - C. Select MIDI Transmit Channel
  - D. Set MIDI Program Transmit Map
  - E. Change Global MIDI continuous controller (CC) links
  - F. Change first Local MIDI Continuous Controller link
  - G. Change second Local MIDI CC link
  - H. Dump MIDI Data (Send all TWIN TUBE data to a MIDI computer, MIDI recorder or another TWIN TUBE)
  - I. Dump Current Program (Send a single program)
  - J. Return to Utility Menu.
4. Foot Controller Setup Menu
  - A. Foot Controller Mode (Six Patch or Ten Patch)
  - B. Programming SETs and PATCHes
  - C. Return to Utility Menu
5. Power Up With Sales Banner On
6. Factory Preset Restore Menu
  - A. Restore unit to factory preset condition
  - B. Return to Utility Menu
7. Show software version number
8. Change the LCD contrast
9. Program Copy

## MAIN UTILITY MENU BLOCK DIAGRAM

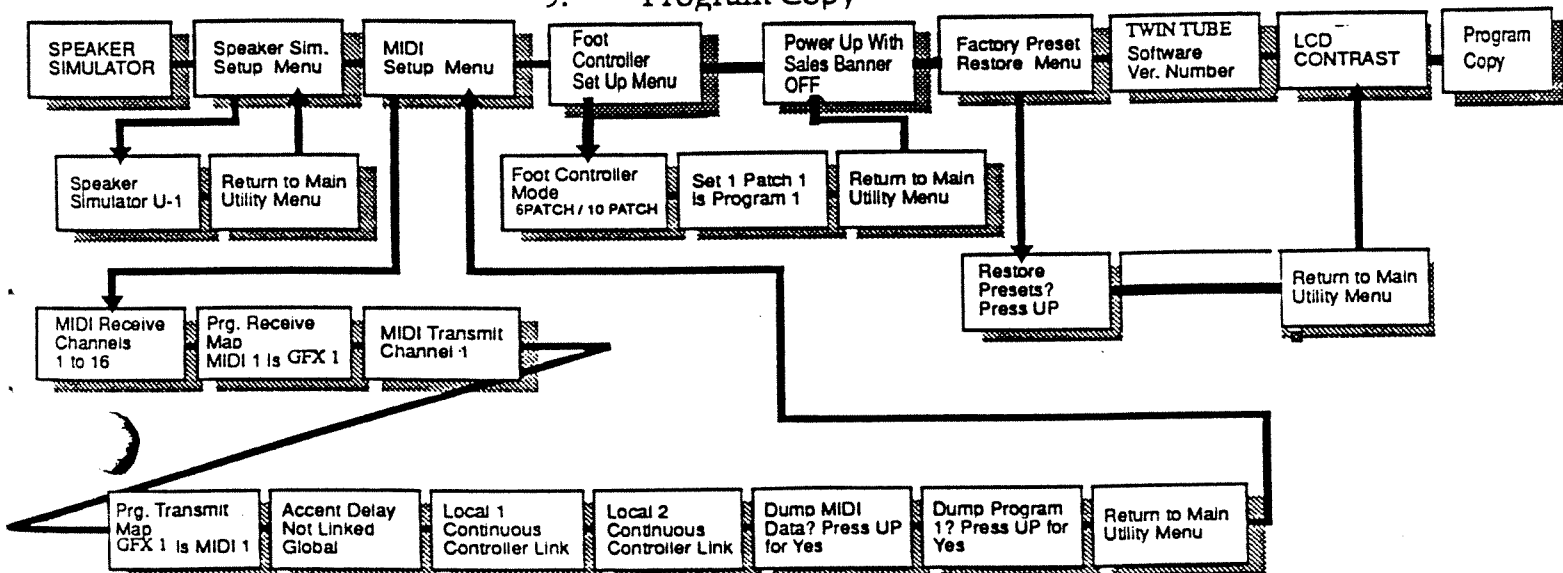

After pressing the utility button, move through the utility functions by pressing the right or left parameter buttons. Exit the utility mode by pressing the UTILITY button again.

## SPEAKER SIMULATOR

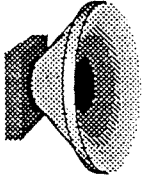

An important part of a good guitar sound is the way that both the amplifier and speaker "color" the sound going through them. The Speaker Simulator electronically emulates different types of speaker / amplifier combinations. This allows you to play the TWIN TUBE directly into the mixer board or tape input, and retain the desirable miked-amplifier sound for recording.

When the UTILITY button is first pressed, the display will read:

Speaker _____ Simltr 1 _____	(example)
---------------------------------	-----------

Use the PARAMETER UP and DOWN buttons to select among the 9 different Speaker Simulator presets and the 5 User Programmable Speaker Simulator presets. Press PARAMETER RIGHT to go to the next Utility item, or UTILITY to exit.

The 9 Speaker Simulator presets are configured as follows:

- |   |  |  |
|---|--|--|
| 1 |  | For general use                                |
| 2 |  | For metal distortion direct into mixer         |
| 3 |  | For power amps or amps that lack high end      |
| 4 |  | For small combo amps or amps that lack low end |
| 5 |  | For bright or midrange amps                    |
| 6 |  | For amps that lack midrange                    |
| 7 |  | For muddy amps                                 |
| 8 |  | To add more low mids or more chunk             |
| 9 |  | To add more highs and mid highs                |

Speaker Simulator Setup Menu

This utility allows you to program your own Speaker Simulator response curves, and store them in User Presets U-1 through U-5. To enter this menu, press PARAMETER DOWN. In the Speaker Simulator menu, the cursor will start under the User preset number. Press PARAMETER UP or DOWN to go to the desired preset number. Press PARAMETER RIGHT, and the cursor will be under the first Simulator Band. Pressing PARAMETER UP or DOWN will increase or decrease the band response, shaping the low response of the simulated speaker (this will make it sound like a larger speaker cabinet). Press PARAMETER RIGHT to go to each of the other Simulator Bands, which each adjust higher speaker response bands. Listen to the changes in the sound. These changes will affect all programs, not just the preset you are on. Press PARAMETER RIGHT after the last Band, and the display will read:

Return to Main  
Utility Menu ↑

Press PARAMETER UP to return to the Utility Menu, or PARAMETER RIGHT to continue editing User Presets. The changes to the Speaker Simulator User Presets are saved automatically.

**MIDI** MIDI is used by music equipment manufacturers to allow different components to communicate with each other. For example, a synthesizer, MIDI controller or MIDI computer could be used to change the volume or program number of all components on the same MIDI channel, including the TWIN TUBE.

There are 128 MIDI functions, called continuous controllers, which can be used to externally control most functions of the TWIN TUBE. See Appendix D, "Standard MIDI Continuous Controllers"

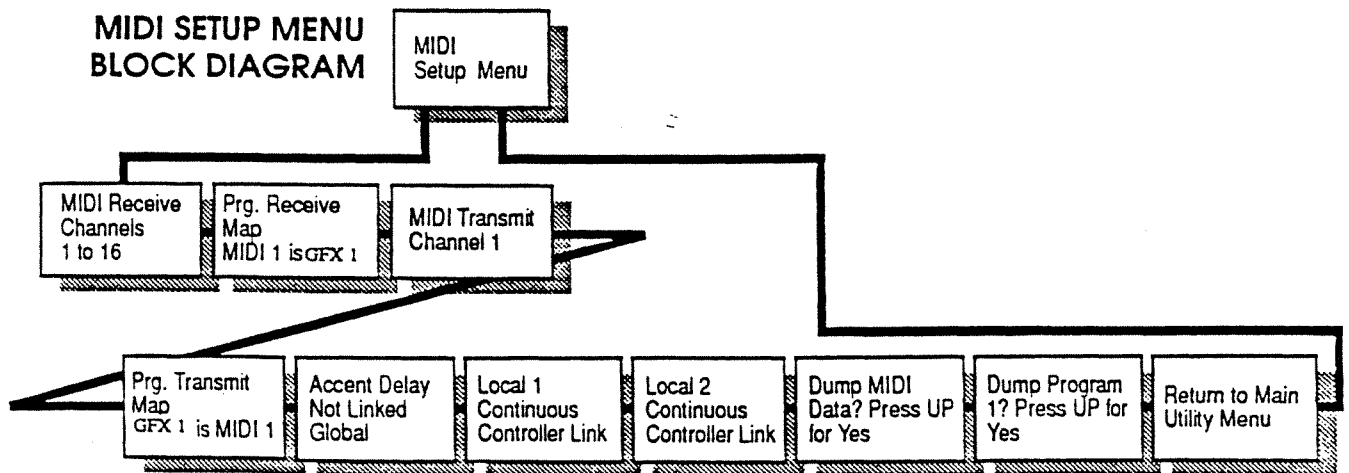

This sub-menu contains all of the functions for setting external communications for the TWIN TUBE; Continuous control pedals MIDI in and out, and Program parameter exporting. Press PARAMETER DOWN to enter the first sub-menu item:

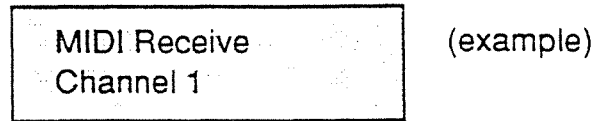

Select MIDI Receive Channel

The TWIN TUBE can receive data from 16 MIDI channels coming through the MIDI input jack from devices which send MIDI data.

Press the PARAMETER UP or DOWN button to select channel 1 through 16, or channels 1 to 16 simultaneously (omni), or "Disabled". MIDI data is received on the indicated channels at all times unless "Disabled" is selected.

Press the RIGHT PARAMETER button to go to the next utility function, or LEFT PARAMETER button to go to the previous utility function.

MIDI Program Receive Map

The TWIN TUBE can respond to Program Change instructions from keyboards, sequencers, or other MIDI controller. Programs on the TWIN TUBE are changed at the same time program changes are made on the MIDI controller.

Use this utility to select which TWIN TUBE program is called up when the MIDI program number is received.

For example, the keyboard may use program 12 for a trumpet sound, but the effects that go with this sound are on program 119 of the TWIN TUBE. Set the MIDI link table to read:

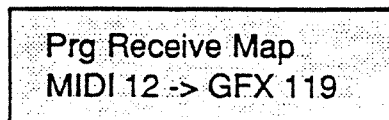

Set this way, whenever the TWIN TUBE receives a MIDI Program 12 on the selected MIDI receive channel, the TWIN TUBE will change to program number 119.

When the cursor is under the number immediately following "MIDI" on the bottom line, the PARAMETER UP and DOWN buttons change the MIDI program numbers and look at the TWIN TUBE program number that is linked to each one.

From the factory, all linkages are set so MIDI programs 1 through 128 are linked to TWIN TUBE programs 1 through 120.

To change a linkage, push the PARAMETER RIGHT button. The cursor moves to the TWIN TUBE program number on the bottom line. Change the program number using the PARAMETER UP and DOWN buttons.

After creating the desired linkages, press the RIGHT PARAMETER button to go to the next utility function, or UTILITY to exit.

#### Select MIDI Transmit Channel

The TWIN TUBE can transmit MIDI data on one of the 16 MIDI channels through its MIDI OUT/THRU port. Upon selecting this utility, the display will show "MIDI Transmit Channel 1".

Press the PARAMETER UP or DOWN button to select channels 1 through 16, or "Disabled". MIDI data will be transmitted on the selected channel whenever a program change is made from either the TWIN TUBE Foot Controller or the front panel, unless "Disabled" is selected.

Press the PARAMETER RIGHT or LEFT button to go to the next or previous Utility function, or press UTILITY to exit the Utility mode.

#### MIDI Program Transmit Map

Use this utility to select which MIDI Program is sent when a TWIN TUBE program is selected from MIDI, the optional TWIN TUBE Foot Controller, or the optional Studio Remote Controller. Data will be sent on the selected MIDI Transmit channel. For example if the link is set as follows:

Prg Transmit Map GFX <u>110</u> -> MIDI 9
--

(example)

then whenever the TWIN TUBE program 110 is selected with either of the available remote controllers, a MIDI Program Change 9 will be sent on the selected MIDI Transmit channel.

When this utility is selected, the cursor is under the number immediately following "GFX" on the bottom line of the display. Press PARAMETER UP or DOWN to select the program number on the TWIN TUBE which you want to link to a MIDI Program number for transmitting. Then press PARAMETER RIGHT to move the cursor to the number next to "MIDI" on the display, and use PARAMETER UP or DOWN to select the MIDI Program number that

will be sent when the TWIN TUBE program is selected.

Press the PARAMETER RIGHT or LEFT button to go to the next or previous Utility function, or press UTILITY to exit the Utility mode.

### Change Global MIDI CC (Continuous Controller)

#### Links

This function links any one TWIN TUBE effect parameter to a MIDI continuous controller (CC). For example, if the volume (normally CC 7) on the MIDI controller is increased, the TWIN TUBE can be programmed to automatically increase the delay time. Here, "Global" means that the link is valid in all programs.

When this utility is selected, the display reads:

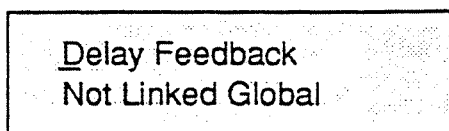

Delay Feedback  
Not Linked Global

This shows that the delay feedback is not linked to any CC. With the cursor on the top line, under the A, press the UP or DOWN PARAMETER button to show other effect parameters and their links. The parameters are listed in alphabetic order. The TWIN TUBE comes from the factory with no Global CC links; all links must be assigned by the user.

To link effect parameters to CC's, decide which effect should be linked to which CC. A list of standard MIDI CCs is in Appendix E.

Press the UP or DOWN PARAMETER button to select the desired effect parameter. Press the RIGHT button and the cursor moves to the bottom line, under "Not Linked". Press the UP or DOWN PARAMETER button to select a CC.

There are 128 CCs, plus channel pressure (ChP). Channel pressure is like a trumpet player or drummer playing harder or softer.

### Change First and Second Local MIDI CC Links

After creating the desired linkages, press the RIGHT PARAMETER button to go to the next utility function, or UTILITY to exit.

Two local CC links (First and Second) are possible per program. These are links which are only valid in a specific program.

Linking continuous controllers to certain parameters gives you the ability to control the sound without having to change programs. As an example, imagine that you are setting up for a live performance, and would like to control the overall volume



on all programs, but also the Tube Saturation and Chorus LFO Sweep Depth on one certain program.

To do this, you would enter the Utility menu and link the Global CC to the Master Level. Exit the Utility menu, and go to the program you wish to link the distortion and the chorus level to. Enter the Utility menu again and link the Tube Saturation parameter to one local controller (Local 1 CC) and the Chorus LFO Sweep Depth to the other (Local 2 CC). Now, for all songs and all presets, you can control your overall volume — and for one particular song, you can use this preset and control the amount of Tube Saturation and Chorus LFO Sweep Depth.

Setup of these Local links is similar to the Global Links described in the previous section. The following differences should be noted:

1. The linkable parameters are listed in the order in which they appear in the program selected. Depending on which program you were in when you entered the Utility mode, the parameters will be different for the local link.
2. After you set up the first local link, pressing PARAMETER RIGHT will move you to the second link setup menu.
3. Remember, these links are valid only for the program number shown at the bottom right of the display. For links valid for all programs, set up the Global CC Link as described in the previous section.

Press the PARAMETER RIGHT button at the end of the Second Local CC Link to go to the next or previous Utility function, or press UTILITY to exit the Utility mode.

The TWIN TUBE comes from the factory with two parameters in each program linked to a Local CC number.

Dump MIDI Data (All Programs) This utility sends all the TWIN TUBE programs to a MIDI computer, a MIDI recorder or to another TWIN TUBE.

When selected, the display reads:

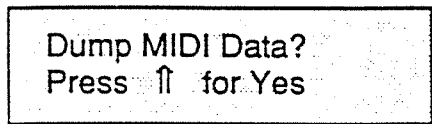

Make sure the receiving device is properly connected to the TWIN TUBE MIDI Out jack and both devices are using the same MIDI channel, then press the PARAMETER UP button. The display will show the message "Transmitting".

To skip this utility, press the RIGHT PARAMETER button.

Dump a Single Program This utility sends the current TWIN TUBE program to a MIDI computer, a MIDI recorder or to another TWIN TUBE. This is a great way to copy a user program off someone else's TWIN TUBE.

When selected, the display will ask if it should dump MIDI data. Make sure the receiving device is properly connected to the TWIN TUBE MIDI OUT/THRU jack and both devices are using the same MIDI channel, then press the PARAMETER UP button. The display will show the message "Transmitting".

To skip or exit this utility, press the RIGHT PARAMETER button, then UP to return to the Utility Menu.

Foot Controller Menu An optional foot controller specifically designed for the TWIN TUBE is available from your DigiTech dealer.

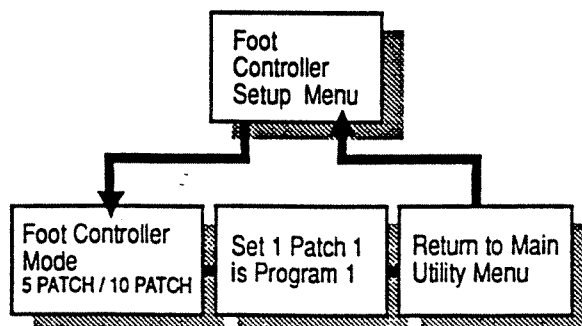

Setting FC Mode (Six Patch or Ten Patch)

Press PARAMETER DOWN at the Foot Controller Setup Menu to reach this utility, which sets the Foot Controller Modes between the Six Patch mode and the Ten Patch mode. When in Ten Patch Mode, the Effects Bypass Switches (2 through 5) will be used for patch selection, and not for effects bypass. Press PARAMETER UP or DOWN to change between the two modes, and press PARAMETER RIGHT.

Programming Sets and Patches

To set up the foot controller Sets and Patches, enter this utility and the display will show:

Set 1 Patch 1 is  
Program 1

(example)

This means that when the Patch 1 numbered switch is pushed on the Foot Controller, if Set 1 is selected, the TWIN TUBE will change to Program 1.

With the cursor under the "1" following "Set", press PARAMETER UP or DOWN to select one of the 10 Sets. Notice as you cycle through the Set numbers, the programs assigned to Patch 1 in that Set are shown on the bottom line of the display.

Once the Set is selected, press PARAMETER UP or DOWN to select one of the six or ten Patches. As the Patches are cycled through, notice that the Program number assigned to that Patch in the current Set is shown.

Once the Patch is selected, press PARAMETER RIGHT to move the cursor to the Program number. Now use PARAMETER UP or DOWN to choose a TWIN TUBE Program number for the Patch. Since there are ten Sets of five to ten Patches each, up to one hundred Patches are available for one-button remote selection.

Instead of being assigned to a Program number, any one of the numbered switches can be programmed to activate the Repeat Hold (infinite echo) function. Choose these Patch settings just like you would choose a Program number, but use the PARAMETER UP button to scroll past Program number 120. Repeat Hold will be the next option, then the display will wrap around to Program number 1 again.

After setting the Foot Controller configuration, press the RIGHT and then UP PARAMETER buttons to go to the next Utility Menu function or UTILITY to exit.

**SETS AND PATCHES  
FACTORY SETTINGS TABLE**

**6 Patch Mode**

Switch	1	2	3	4	5	6
Set 1	1	2	3	4	5	6
Set 2	7	8	9	10	11	12
Set 3	13	14	15	16	17	18
Set 4	19	20	21	22	23	24
Set 5	25	26	27	28	29	30
Set 6	31	32	33	34	35	36
Set 7	37	38	39	40	41	42
Set 8	43	44	45	46	47	48
Set 9	49	50	51	52	53	54
Set 10	55	56	57	58	59	60

Program Numbers

**10 Patch Mode**

Switch	1	2	3	4	5	6	7	8	9	10
Set 1	1	2	3	4	5	6	61	62	63	64
Set 2	7	8	9	10	11	12	65	66	67	68
Set 3	13	14	15	16	17	18	69	70	71	72
Set 4	19	20	21	22	23	24	73	74	75	76
Set 5	25	26	27	28	29	30	77	78	79	80
Set 6	31	32	33	34	35	36	81	82	83	84
Set 7	37	38	39	40	41	42	85	86	87	88
Set 8	43	44	45	46	47	48	89	90	91	92
Set 9	49	50	51	52	53	54	93	94	95	96
Set 10	55	56	57	58	59	60	97	98	99	100

Program Numbers

Factory Preset Restore Menu

This utility restores all factory MIDI linkages, deletes all user programs and clears out all footswitch patches.

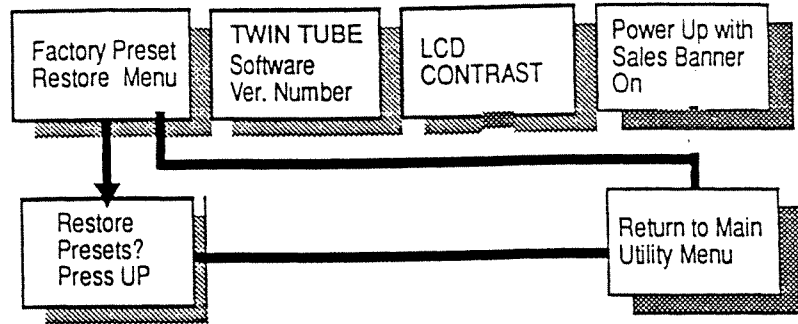

When selected, the display reads:

Restore Presets?  
Press ↓ for Yes

If the PARAMETER UP button is pressed, the display gives the following warning:

Are You Sure?  
Press ↑ for Yes

Press PARAMETER UP to confirm, or press any other front panel button to cancel the restore command.

SOFTWARE VERSION

This function displays the software version installed on the TWIN TUBE. The display will read:

DigiTech TWIN TUBE  
Version 1.0

This is mostly for servicing information. DigiTech reserves the right to upgrade software at any time without incurring any obligation to install the same upgrades on products previously manufactured. See "Warranty".

Change LCD Contrast

This utility changes the contrast on the liquid crystal display. When selected, the display reads:

LCD Contrast  
1

(example)

Press the PARAMETER UP or DOWN buttons to change the contrast from 1 to 10. When finished, press the RIGHT PARAMETER button to go to the next utility function.

## THE FOOT CONTROLLER (OPTIONAL)

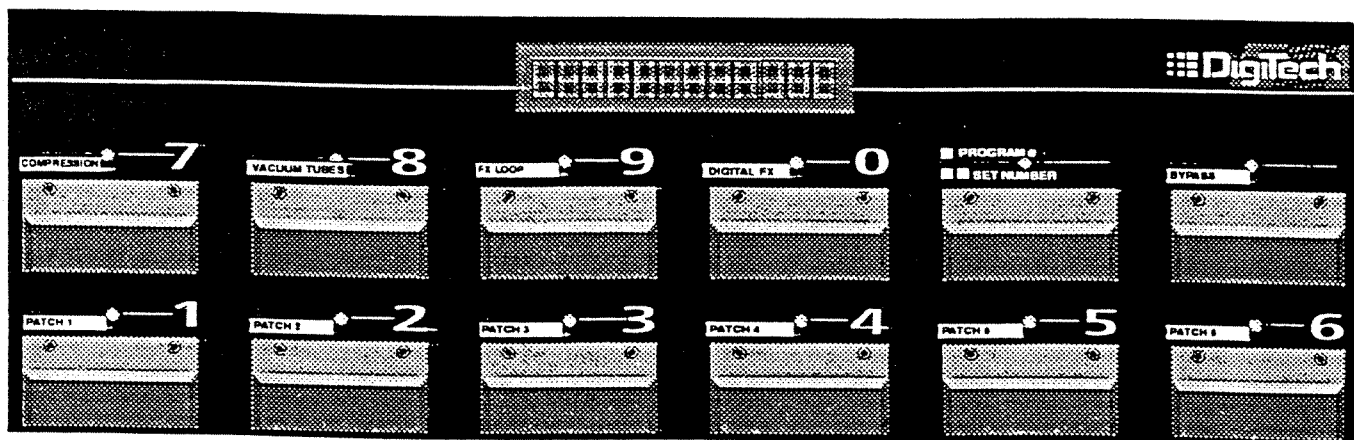

**Display** The 20 character vacuum fluorescent display is divided into two areas: the first three characters display the program number of the current patch, and the right-most sixteen characters display the title of the patch. The title mirrors the title that is stored in the main unit. In some modes, the display will issue prompts to the user rather than the program title. (Due to incompatibilities of the display types, certain characters look different on the Foot Controller display than on the front panel of the TWIN TUBE).

**Bypass** The right-most switch in the upper row bypasses the entire unit, the same way as the front panel BYPASS switch. The BYPASS LED will light while the unit is bypassed.

### OPERATING MODES

The TWIN TUBE Foot Controller operates in two modes, Six Patch and Ten Patch modes. A Patch is the relationship between a Foot Controller button and a TWIN TUBE Preset (page 28). The function of most of the pedal switches depends on the current mode of operation. Choosing the mode that you want to use is done through the Utility Menu (page 17).

Six Patch Mode  
Numbered  
Switches 1 — 6  
(Patch 1 — Patch 6)

These switches access any of six pre-programmed Patches from the current SET. The LED above the selected switch will light to indicate the current Patch. If a PATCH switch is pressed when the corresponding Patch is already selected, the last Patch used will become the current Patch. In addition to choosing specific Program numbers, PATCH switches may be programmed to perform the repeat hold and effects loop bypass functions.

There are 10 SETS of Patches available. To change to a different SET number, press the PROGRAM #/ SET NUMBER switch twice, then select a SET number with one of the numbered switches 1 to 0 (zero is equivalent to #10)

Upper Row Switches  
(Individual Effects Bypass)

When in Six Patch mode, the upper 4 numbered switches enable and disable the indicated effect if that effect is available in the current Patch. The LED above the EFFECT switch will light if the effect is active.

Ten Patch mode  
Numbered Switches 1 - 0

In this mode, each of the ten numbered switches becomes a PATCH (the switch numbered 0 corresponds to the tenth Patch). The rest of the functioning is the same as described in the Patch 1 - Patch 6 section, except that the Effects Bypass function is not available on the lower switches.

Program Number  
Random Access  
Numbered Switches 1 - 0

To randomly access any program in the TWIN TUBE, press the PROGRAM # / SET NUMBER switch once. The display will show:

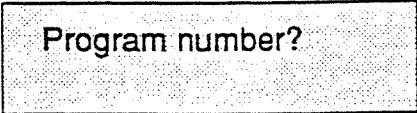

Program number?

Enter the number of the program you wish to select.

For example, to choose program 36:

- Press PROGRAM # / SET NUMBER once
- Display reads "Program number?"
- Press numbered switches, in order, 0-3-6

The TWIN TUBE will go to program 36, then automatically return to the current Patch mode.

Examples: For program 128, press 1-2-8. For program 45, press 0-4-5 or 4-5. For programs starting with 0 or 1, such as 12, press 0-1-2 or 1-2 and wait two seconds, or 1-2-PROGRAM #/SET #.

## Programming

All programming for the TWIN TUBE Foot Controller is done through the TWIN TUBE front panel programming buttons in the Utility mode. The Foot Controller menu in the Utility Menu allows the user to assign any program, the repeat hold function, or effects loop bypass to any of the six or ten Patches in each of the ten Sets, giving a total of sixty or one hundred patches. See the Utility Menu section of the manual (page 17) for details of programming in the Utility mode.

Note: If you choose a SET with ten Patches, and then change to Six Patch Mode, Patches 6 through 0 (10) will still be there, but you won't be able to access them via the numbered switches until you change back to Ten Patch Mode.

# THE EFFECTS LOOP

---

The effects loop is located after the analog effects, and before the digital effects. There are two options: IN or OUT.

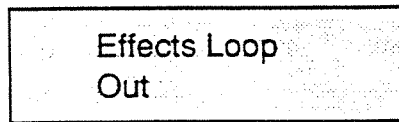

When In is chosen, the whole signal comes from the Noise Gate, flows through the external effect(s), and is returned to the digital section of the TWIN TUBE.

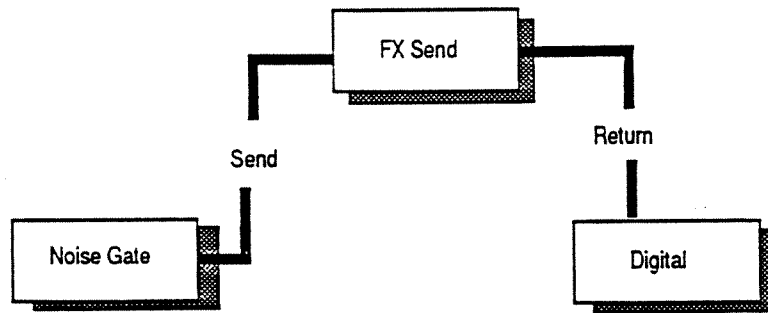



## APPENDIX A

Cmp + Tub + Eq + NG + D + Mx + SS  
Cmp + Tub + Eq + NG + Ch + Mx + SS  
Cmp + Tub + Eq + NG + Fl + Mx + SS

Effects Parameter	Parameter Range
Compression	ON or BYPASSED
Compression Amount	0 to 31
Compression Level	1 to 7
Vacuum Tubes	ON or BYPASSED
Tube Bias	CLEAN TUBE or DIRTY TUBE
Tube Gain	0.6 to 11.0
Tube Saturation	0.6 to 11.0
Graphic EQ	ON or FLAT
63 Hz Band	± 12 dB in 1 dB steps
160 Hz Band	± 12 dB in 1 dB steps
400 Hz Band	± 12 dB in 1 dB steps
1 kHz Band	± 12 dB in 1 dB steps
2.5 kHz Band	± 12 dB in 1 dB steps
6.3 kHz Band	± 12 dB in 1 dB steps
16 kHz Band	± 12 dB in 1 dB steps
Master Volume	± 12 dB in 1 dB steps
Noise Gate	ON or BYPASSED
Gate Threshold	1 to 16
Effects Loop	OUT or IN
Digital Effects	ON or BYPASSED
Effects Type	Delay Chorus Flange
<b>Delay</b>	
Delay Time	0.5 to 500 milliseconds
Delay Feedback	0% to 99%
Mix Wet Dry	100% Wet to 100% Dry
<b>Chorus</b>	
Chorus Delay	0.0 to 100 milliseconds
LFO Sweep Rate	0.00 Hz to 5.00 Hz
LFO Sweep Depth	0% to 100%
LFO Wave Form	Sawtooth Sine Log
Mix Wet Dry	100% Wet to 100% Dry
<b>Flange</b>	
Flange Delay	0.0 to 15.0 milliseconds
LFO Sweep Rate	0.00 Hz to 5.0 Hz
LFO Sweep Depth	0% to 100%
LFO Wave Form	Sawtooth, Sine, Log
Flange Feedback	0% to 99%
Mix Wet Dry	100% Wet to 100% Dry

# APPENDIX B

# USER PROGRAM SHEETS

# TWIN TUBE

Photocopy this page and record your programs' parameters

Program Number: \_\_\_\_\_ Configuration: \_\_\_\_\_ Title: \_\_\_\_\_

_____	_____	_____	_____	_____
_____	_____	_____	_____	_____
_____	_____	_____	_____	_____
_____	_____	_____	_____	_____
_____	_____	_____	_____	_____
_____	_____	_____	_____	_____
_____	_____	_____	_____	_____
_____	_____	_____	_____	_____
_____	_____	_____	_____	_____
_____	_____	_____	_____	_____

Program Number: \_\_\_\_\_ Configuration: \_\_\_\_\_ Title: \_\_\_\_\_

_____	_____	_____	_____	_____
_____	_____	_____	_____	_____
_____	_____	_____	_____	_____
_____	_____	_____	_____	_____
_____	_____	_____	_____	_____
_____	_____	_____	_____	_____
_____	_____	_____	_____	_____
_____	_____	_____	_____	_____
_____	_____	_____	_____	_____
_____	_____	_____	_____	_____

Program Number: \_\_\_\_\_ Configuration: \_\_\_\_\_ Title: \_\_\_\_\_

_____	_____	_____	_____	_____
_____	_____	_____	_____	_____
_____	_____	_____	_____	_____
_____	_____	_____	_____	_____
_____	_____	_____	_____	_____
_____	_____	_____	_____	_____
_____	_____	_____	_____	_____
_____	_____	_____	_____	_____
_____	_____	_____	_____	_____
_____	_____	_____	_____	_____

## APPENDIX C

# STANDARD MIDI CONTINUOUS CONTROLLERS

---

CONTROLLER NUMBER	CONTROLLER FUNCTION
0	Undefined
1	Modulation wheel or lever
2	Breath controller
3	Undefined
4	Foot controller
5	Portamento time
6	Data entry MSB
7	Main volume
8	Balance
9	Undefined
10	Pan
11	Expression controller
12 through 15	Undefined
16 through 19	General purpose controllers 1 through 4
20 through 31	Undefined
32 through 63	LSB for values 0 through 31
64	Damper pedal (sustain)
65	Portamento
66	Sostenuto
67	Soft pedal
68	Undefined
69	Hold 2
70 through 79	Undefined
80 through 83	General purpose controllers 5 through 8
84 through 91	Undefined
92	Tremolo depth
93	Chorus depth
94	Celeste depth
95	Phaser depth
96	Data increment
97	Data decrement
98	Non-registered parameter number LSB
99	Non-registered parameter number MSB
100	Registered parameter number LSB
101	Registered parameter number MSB
102 through 121	Undefined
122 through 127	Channel mode messages

Reprinted by permission of the MIDI Manufacturers Association  
12439 Magnolia Blvd, Suite 104, North Hollywood, CA 91607  
(818) 505 8964

## APPENDIX D

# DOD / DIGITECH ELECTRONICS SYSTEM EXCLUSIVE FORMAT

---

**INTRODUCTION** The DOD/DigiTech Electronics System Exclusive Format facilitates use and control of various signal processing devices manufactured by DOD/DigiTech Electronics. The format allows different types of data transfer with capability for future expansion.

Currently, a DOD/DigiTech digital signal processor can receive machine-dependent microcode, and user-programmed parameters can be received from and dumped to external devices.

Device Type	OCH
Procedure Type	00H Request for program dump (all programs)
	40H Download microcode
	41H Download program dump (all programs)
<b>GENERAL FORMAT</b>	1111 0000 System-exclusive status byte
	0000 0000 DOD/DigiTech manufacturer's
	0000 0000 ID number
	0001 0000 (00H 00H 10H)
	0000 nnnn Unit number; nnnn + 1 equals the channel number
	0ttt tttt device type
	0ppp pppp procedure type
	0ddd dddd
	0ddd dddd Procedure data
	0ddd dddd
	0ddd dddd
	1111 0111 End-of-exclusive status byte

DEFINITIONS

- Unit Number Internal representation of the channel to which the receiving device is listening. Used to communicate to different devices of the same type connected to a common MIDI line. This byte is ignored if the receiving device is set to omni.
- Device Type Specifies the DOD/DigiTech product receiving communication.
- Procedure Type Up to 128 procedure commands specifying which procedures within a device are to be executed. The first 64 (00H to 3FH) are universal procedures that apply to all device types. The second 64 (40H to 7FH) are specific to a particular device type.
- Data Transmits data specified by the executed procedure. See "Specific Formats" for the expected data format.

(Microcode is packed into groups of four data bytes. Specific information on the TWIN TUBE microcode programming is proprietary information of DOD/DigiTech Electronics Corporation.)

SPECIFIC FORMATS FOR THE GSP-21 PRO



Sending Microcode to the GSP-21 PRO

- 1111 0000 System-exclusive status byte
- 0000 0000 DOD/DigiTech ID
- 0000 0000
- 0001 0000
- 0000 nnnn Unit number (+ 1 = channel)
- 0000 1010 TWIN TUBE device
- 0100 0000 Send microcode to TWIN TUBE
- 0ddd dddd Data byte 1
- 0ddd dddd Data byte 2
- 0ddd dddd (Groups of four, 128 total possible)
- 0ddd dddd
- 1111 0111 End-of-exclusive status byte

Requesting User Programming Dump (All Programs)

- Device requesting dump:
- 1111 0000 System-exclusive status byte
  - 0000 0000 DOD/DigiTech ID
  - 0000 0000
  - 0001 0000
  - 0000 nnnn Unit number (+ 1 = channel)
  - 0000 1100 TWIN TUBE device
  - 0000 0000 Procedure (dump all programs)
  - 1111 0111 End-of-exclusive status byte

TWIN TUBE dump response:

1111 0000	System-exclusive status byte
0000 0000	
0000 0000	DOD/DigiTech ID
0001 0000	
0000 nnnn	Unit number (+ 1 = channel)
0000 1100	TWIN TUBE device
0100 0001	Download all programs
0ddd dddd	Data byte 1
0ddd dddd	Data byte 2
"	
"	
0ddd dddd	Data byte 10,801
0ddd dddd	Data byte 10,802
1111 0111	End-of-exclusive status byte

Downloading Dumped  
User Programs (All  
Programs)

1111 0000	System-exclusive status byte
0000 0000	
0000 0000	DOD/DigiTech ID
0001 0000	
0000 nnnn	Unit number (+ 1 = channel)
0000 1010	TWIN TUBE device
0100 0001	Download all programs
0ddd dddd	Data byte 1
0ddd dddd	Data byte 2
"	
"	
0ddd dddd	Data byte
0ddd dddd	Data byte
1111 0111	End-of-exclusive status byte

# TWIN TUBE MIDI IMPLEMENTATION CHART

TWIN TUBE  
DIGITECH TWIN TUBE Tube Guitar Preamp

Date: XXXX  
Version: 1.0

FUNCTION		TRANSMITTED	RECOGNIZED	REMARKS
Basic Channel	Default Changed	1 - 16 1 - 16	1 - 16 1 - 16	Memorized
Mode	Default Messages Altered	Mode 3 x	Mode 3 x	Omni Off
Note Number	True Voice	x	x	
Velocity	Note on Note off	x x	o o	
After Touch	Keys Channels	x x	o o	
Pitch Bender		x	o	
Control Change		x	o	
Program Change	True #	0 - 120	0 - 120 1 - 121	Internally mappable
System Exclusive		o	o	
System Common	Song Position Song Select Tune	x x x	x x x	
System Real-Time	Clock Commands	x x	x x	
Auxiliary Messages	Local ON/OFF All Notes OFF Active Sense Reset	x x x x	x x x x	
Mode 1: Omni On, Poly Mode 3: Omni Off, Poly		Mode 2: Omni On, Mono Mode 4: Omni Off, Mono	o = Yes x = No	

## TWIN TUBE MANUAL ADDENDUM

The following changes should be made in the GFX-1 TWIN TUBE Owners Manual.

### Page 2 INTRODUCTION

Last sentence "... five of the digital analog effects, ..."  
Delete "of the digital analog".

### Page 6 OUTPUT JACKS

Use B Output for MONO. Do Not mix the A and B jacks for mono sound, the effects disappear.

### Page 9 CREATING PROGRAMS

The effects that are currently off are not shown at all, they do not appear as lower-case letters.

---

### Page 13 COMPARE

The TWIN TUBE does not operate with an optional studio remote controller.

### Page 15 MASTER VOLUME

There are actually 2 master volume controls; Level with tubes and Level without tubes. This will depend on whether the tubes are enabled or not. This allows a balanced level between having the tubes on or off.

### Page 16 FLANGE DELAY TIME

The Depth parameter is measured in percentage not in milliseconds.

### Page 23 Last Paragraph

The TWIN TUBE comes from the factory with NO parameters linked to a Local CC number.

### Page 25 2nd to last paragraph

The TWIN TUBE does not have a Repeat Hold function

### Page 29 3rd to last paragraph

The TWIN TUBE only has 120 programs not 128.

### Page 31 DELAY

0.1 to 500 milliseconds

### Page 34 through 36 MIDI SYSTEM EXCLUSIVE

The listing has several errors. Please contact the factory for a correct listing of the TWIN TUBE System Exclusive Format.